

VC731005 MUK Rev1

morphy richards®

smart ideas for your home



Supervac sleek Cordless Vacuum Cleaner

 Please read and keep these instructions for future use

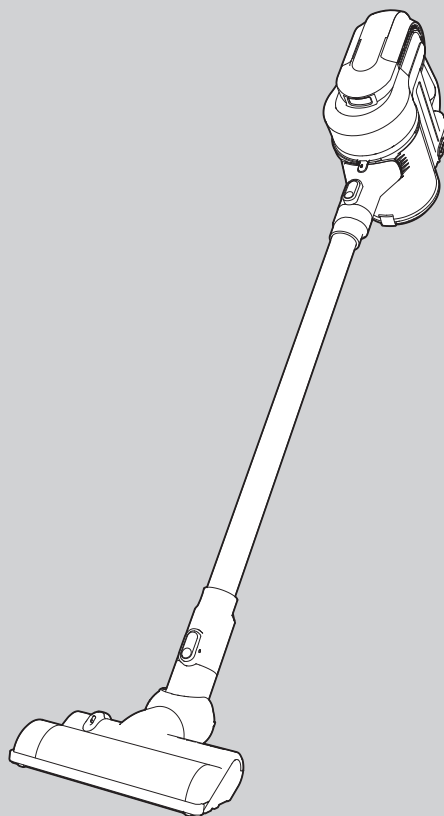

CHARGE THE PRODUCT FULLY BEFORE FIRST USE

For competitions, product hints and tips
and more join us at



www.morphyrichards.co.uk/blog



www.facebook.com/morphyrichardsuk



[@loveyourmorphy](https://twitter.com/loveyourmorphy)

www.morphyrichards.com

* Register online for your 2 year guarantee. See back of this instruction book for details. (UK and Ireland customers only)

Health and Safety

The use of any electrical appliance requires the following common sense safety rules.
Please read these instructions carefully before using the product.

- **WARNING: Whenever the cleaner is in use, due to the risk of entrapment in rotating parts, keep loose clothing, hair, fingers etc. away from the brush bar, nozzle and any handheld accessories.**
- **WARNING: Disconnect from the mains supply and remove the handheld vacuum cleaner (12) before carrying out any routine maintenance, such as cleaning any blockages, changing any filters or accessing the motorised floor brush.**
- This appliance can be used by children aged from 8 years and above and persons with reduced physical, sensory or mental capabilities, or lack of experience and knowledge, if they have been given supervision or instruction concerning the use of the appliance in a safe way and understand the hazards involved.
- Only use the mains adaptor supplied with the unit.
- Children shall not play with the appliance.
- Cleaning and user maintenance shall not be undertaken by children without supervision.

Personal safety

- **WARNING: Only lift the product by the handle (2) and never pick the cleaner up by the motorised floor brush.**
- **WARNING: Misuse of the appliance could cause personal injury.**
- To prevent accidental contact with the rotating brush, always remove the handheld unit before fitting, removing or cleaning the motorised floor brush (25).
- Never use in the presence of explosive liquid or vapours.
- Never pick up inflammable or poisonous liquids such as petrol, copier toner or other volatile substances. Never pick up acids, asbestos or asbestos dust.
- Never touch the adaptor, product or cable with wet hands.
- Unprofessional repairs can be dangerous for users.
- To protect against fire, electric shock and personal injury, do not immerse cord, mains adaptor or cleaner in water or other liquid.
- The appliance must never be left running unsupervised.

Location

- Do not use or keep this product outside.
- Do not store the appliance near hot surfaces eg. ovens or heating appliances.

Product safety

- This appliance is not intended for liquid/wet pick up.
- Never use the appliance without the filter being installed.
- Never use the appliance to vacuum hot ashes, broken glass, sharp objects or liquids.
- Never modify the cleaner in any way.
- Use only Morphy Richards spare parts and accessories.

Electrical requirements

- Check that the voltage on the rating plate of the mains adaptor corresponds with your house electricity supply which must be A.C. (Alternating Current).
- The battery is not a serviceable item. Remove at the end of the product's life for recycling.

Contents

Health and safety	2
Electrical requirements	2
Product overview / Features	4
Triple functionality	5
Set up and charging	5
Upright vacuuming: assembly	6
Using in upright mode	6
Handheld vacuum cleaning	7
Extended reach handheld vacuum cleaning	8
Using the attachments	8
Maintenance	8
Maintenance - emptying the dust canister	9
Maintenance - canister filter	9
Maintenance - main filter(s)	10
Maintenance - motorised floor brush	10
Maintenance - troubleshooting	11
Disposal	11
Contact us	11
Guarantee	12

Product overview

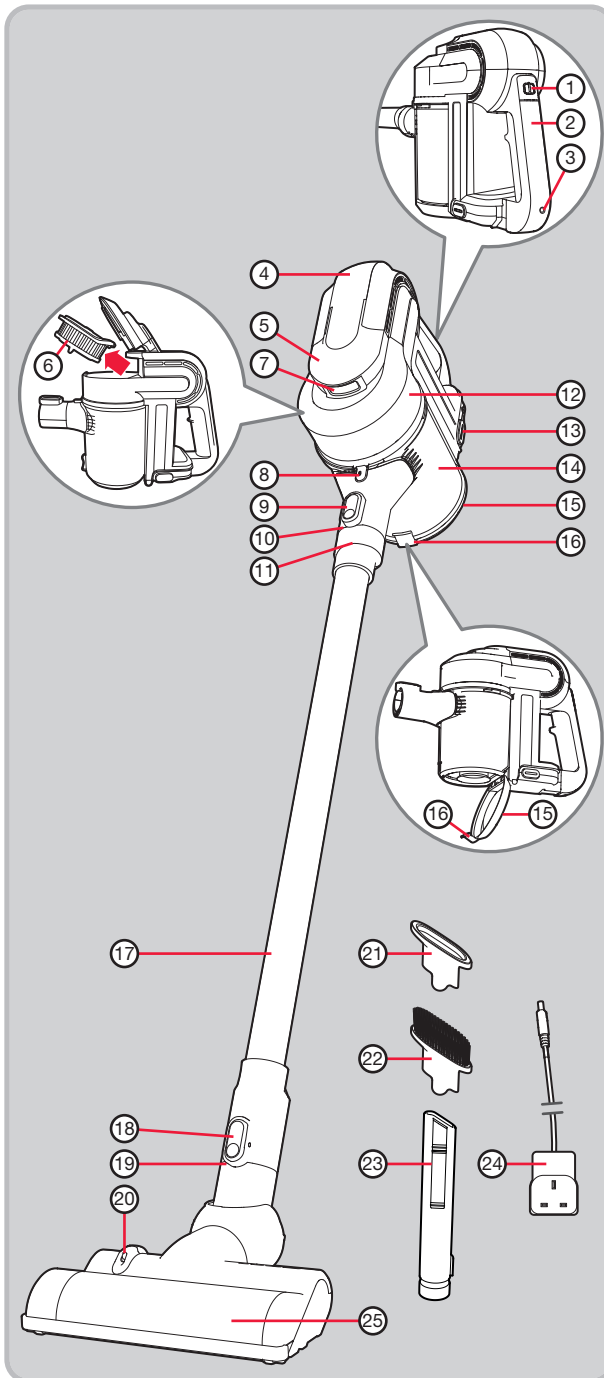

Features

- (1) On/Off button
- (2) Handheld vacuum cleaner handle
- (3) Charging inlet
- (4) Charging / power indicator lights
- (5) Filter access lid
- (6) Circular pleated filter
- (7) Filter access lid release button
- (8) Dust canister release button
- (9) Extension tube release button
- (10) Handheld vacuum cleaner suction inlet
- (11) Extension tube handheld connection end
- (12) Handheld vacuum cleaner
- (13) Battery with release buttons
- (14) Dust canister
- (15) Dust canister swing base
- (16) Dust canister swing base release catch
- (17) Extension tube
- (18) Floor brush release button
- (19) Extension tube suction end
- (20) Floor brush light
- (21) Upholstery brush
- (22) Dusting brush
- (23) Crevice tool
- (24) Mains adaptor
- (25) Motorised floor brush

Triple functionality

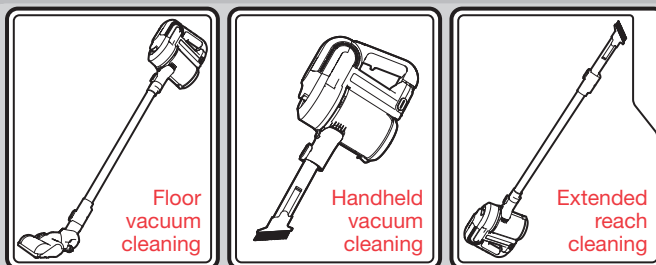

Your vacuum cleaner can easily be configured into three different cleaning modes:

- Upright vacuum cleaner for floors and carpets.
- Handheld vacuum cleaner (12) which can be carried with you whilst cleaning hard to reach places.
- Extended reach vacuum cleaner (12) for cleaning high coving etc.

Set up and charging

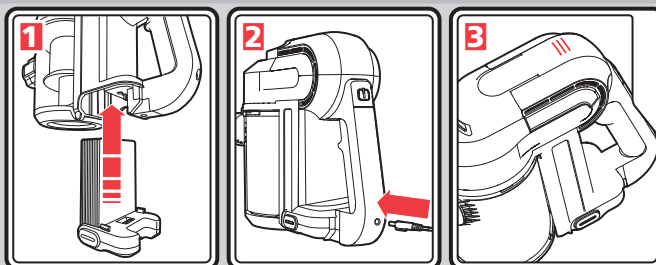

Charge the product fully before first use.

- 1** Align the grooves on the sides of the battery (13) with the ridges inside the battery compartment located on the underside of the handheld vacuum cleaner (12). Slide the battery in until it clicks into place, ensuring the electrical connectors marry together.

The battery will not need to be removed again unless:

- a) the product is undergoing maintenance or cleaning;
- b) the product reaches the end of its useful life.

- 2** Insert the mains adaptor (24) into the charging inlet (3) on the back of the handheld vacuum cleaner handle (2). Connect the mains adaptor into the mains supply.

- 3** The charging / power indicator lights (4) will illuminate and flash. There are three charging lights that will illuminate in turn as the product charges. When charging is complete, the lights will extinguish. A full charge may take 4 hours.

When fully charged, disconnect the mains adaptor from the charging inlet and unplug the mains adaptor from the mains supply.

Upright vacuuming: assembly

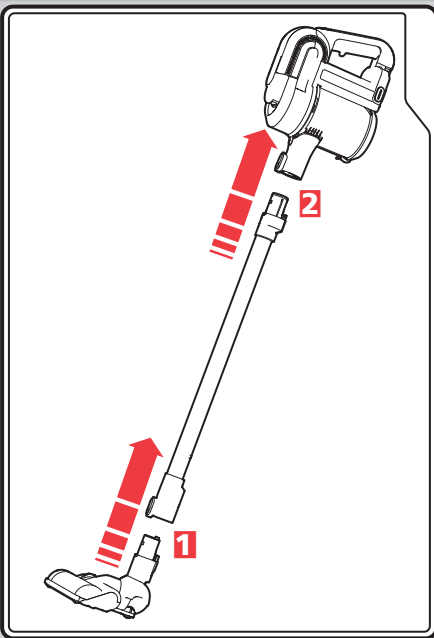

- 1** Push the neck of the motorised floor brush (25) into the extension tube suction end (19) (with the female electrical connector) until it clicks into place, ensuring the electrical connectors marry together.
- 2** Push the extension tube handheld connection end (11) (with the male electrical connector) into the handheld vacuum cleaner suction inlet (10) until it clicks into place, ensuring the electrical connectors marry together.

Using in upright mode

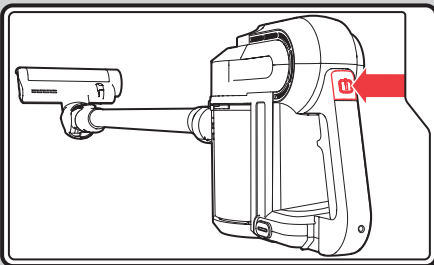

Assemble the product for upright vacuum cleaning (see 'Upright vacuuming: assembly', above).

Turn the product On by pressing the On/Off button (1).

If the motorised floor brush (25) is fitted, the brush will rotate and the floor brush light (20) will illuminate.

NOTE: When the fully charged product is switched on, all three light array bars and the word ON will illuminate (see charging / power indicator lights (4)). As the battery discharges during use, the number of illuminated bars will reduce until just the word ON is illuminated. The ON illumination will start to flash when the battery is almost empty, and within one minute the product will automatically stop and all lights will extinguish. The product must then be recharged.

Handheld vacuum cleaning

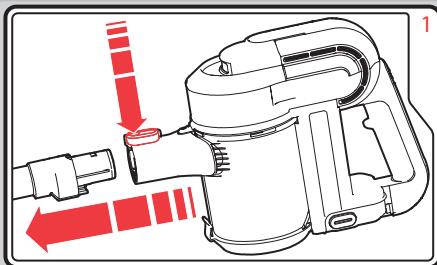

This function is ideal for cleaning stairs, curtains, upholstery and hard to reach places.

If necessary, to separate the extension tube (17) from the handheld vacuum cleaner (12), press the extension tube release button (9) and pull the extension tube away from the handheld vacuum cleaner.

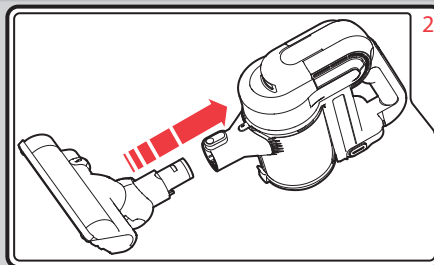

If you wish to use the motorised floor brush (25) directly on the handheld vacuum cleaner (12), you must detach the motorised floor brush from the extension tube (17).

To attach the motorised floor brush to the handheld vacuum cleaner, push the neck of the motorised floor brush (with the male electrical connector) into the handheld vacuum cleaner suction inlet (10) until it clicks into place, ensuring the electrical connectors marry together.

To separate the motorised floor brush from the handheld vacuum cleaner, press the extension tube release button (9) and pull the motorised floor brush away from the handheld vacuum cleaner.

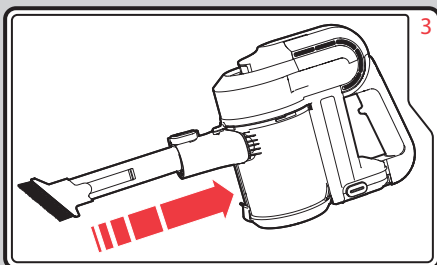

Alternatively, you may wish to use the crevice tool (23) and dusting brush (22) or upholstery brush (21) in place of the motorised floor brush (25).

The crevice tool fits directly into the suction inlet (10) on the handheld vacuum cleaner (12) until a click is heard. To remove it again, press the extension tube release button (9).

To use the dusting brush (22) or upholstery brush (21), they must be secured onto the end of the already fitted crevice tool.

Extended reach handheld vacuum cleaning

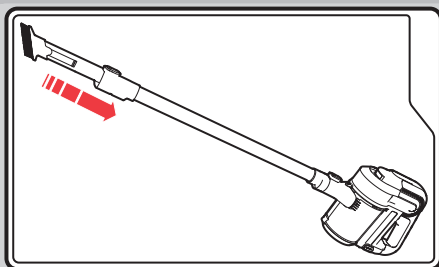

For extra reach whilst cleaning high areas like coving etc, push the crevice tool and dusting brush or upholstery brush into the extension tube suction end (19) and attach the extension tube (17) to the handheld vacuum cleaner. To remove the accessory again, press the floor brush release button (18).

Using the attachments

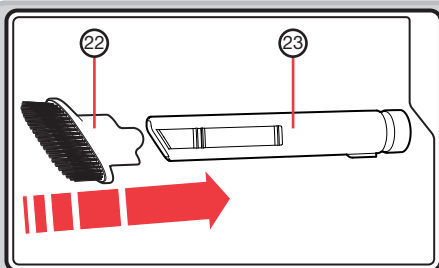

Crevice tool and brushes

Crevice tool (23) for awkward places, corners and behind radiators etc. This tool is also useful on stairs.

Dusting brush (22) for carpet, upholstery and stairs etc.

Upholstery brush (21) for upholstery and bedding etc.

The dusting brush (22) or the upholstery brush (21) can be attached to the crevice tool (23). Slide the brush on to the end of the crevice tool until it clicks into place, as shown above.

Maintenance

WARNING: Always remove the mains adaptor (24) from the mains supply and the battery (13) from the handheld vacuum cleaner (12) before undertaking any maintenance or cleaning procedures.

Your cleaner is manufactured to withstand normal day-to-day use, but an occasional wipe over with a damp cloth will help maintain its good looks. Take care not to get the electrical connections wet.

Abrasive cleaners should not be used.

Maintenance - emptying the dust canister

Empty the dust canister (14) regularly even if it does not look full, this will maintain the performance.

To ensure optimum suction and performance, we recommend that the canister is only filled to the line shown on the side of the canister.

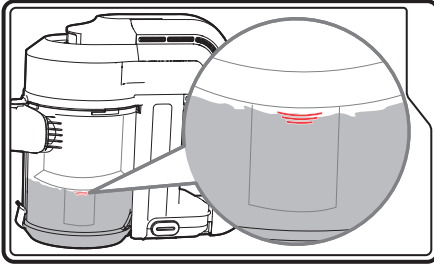

The dust canister can be quickly emptied whilst still attached to the handheld vacuum cleaner (12). To do this, use the dust canister swing base release catch (16) to open the dust canister swing base (15).

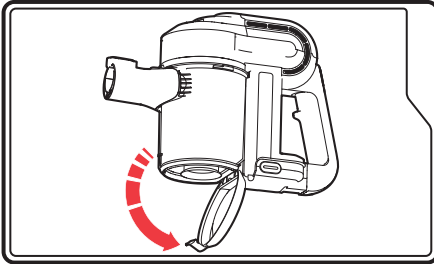

Empty the dirt from inside the dust canister and push the swing base closed again.

Maintenance - canister filter

The guarantee may be invalidated if the motor is damaged due to: using the appliance without the filter(s) installed; not cleaning the filter(s); or not replacing a damaged filter.

Cleaning the dust canister filter

To maintain suction, the perforated cyclone filter in the dust canister must be cleaned during each dust canister empty.

If the perforated cyclone filter becomes clogged, it may be necessary to remove the dust canister to clean it (follow steps below).

1. Remove the extension tube (17), motorised floor brush (25) or crevice tool (23) from the handheld vacuum cleaner (12) by pressing the extension tube release button (9) and pulling the accessory away.
2. Press the dust canister release button (8) and twist the dust canister (14) by pushing the handheld vacuum cleaner suction inlet (10) clockwise (if viewing it from above).

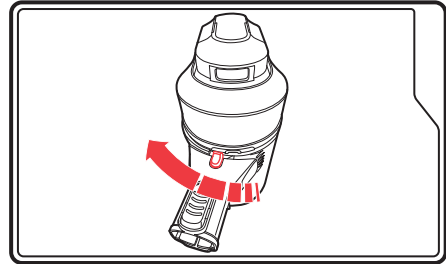

3. Remove the dust canister. Brush the perforated cyclone filter gently to remove any hairs or fibres.
4. When refitting the dust canister, locate it into the correct position before rotating back into the locked position.

Maintenance - main filter(s)

The guarantee may be invalidated if the motor is damaged due to: using the appliance without the filter(s) installed; not cleaning the filter(s); or not replacing a damaged filter.

Cleaning the main filter(s)

To maintain suction, the main filter(s) must be cleaned each time the dust canister (14) is emptied.

1. Follow 'Emptying the dust canister'.
- 1 Press the filter access lid release button (7) and open the filter access lid (5).

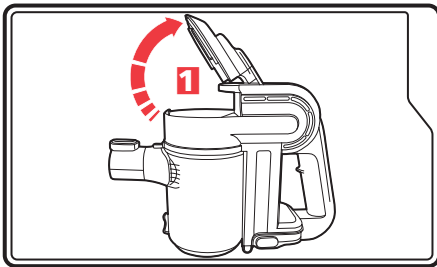

- 2 Lift out the circular pleated filter (6). Every month, wash the pleated filter in luke-warm water and thoroughly air dry before re-fitting.

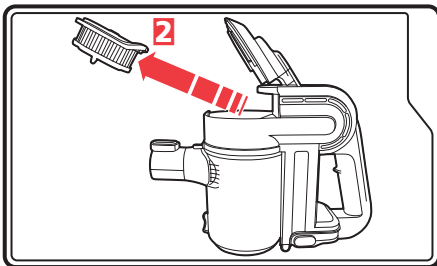

- 3 Remove the tubular foam filter (6a) from the circular pleated filter (6). Wash the tubular foam filter in luke-warm water and thoroughly air dry before re-fitting.

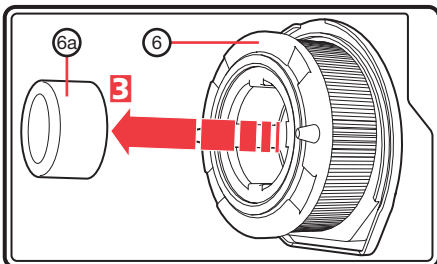

IMPORTANT: Do not wash the filter(s) with hot water or detergents.

IMPORTANT: Do not use heated appliances to dry the filter(s).

2. Replace the filters into the handheld vacuum cleaner (12) and close the filter access lid (5), ensuring it clicks closed.

IMPORTANT: Never use the product without the circular pleated filter (6) and the tubular foam (6a) filter fitted.

Maintenance - motorised floor brush

If the motorised floor brush (25) is stalled, eg. by a foreign object or if used on very deep pile carpet, switch off, disengage the motorised floor brush and then remove the cause of the stall. Leave for a few minutes to allow the floor brush protection to self reset.

To clean the motorised floor brush, turn the unit off, press the floor brush release button (18) and pull the motorised floor brush away from the extension tube (17).

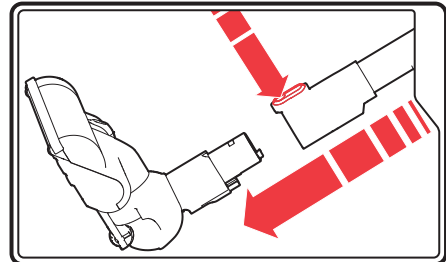

Turn the motorised floor brush (25) over to inspect the rotating brush bar (25c).

Push the locking button (25a) on the brush bar cover (25b) forward to unlock the cover.

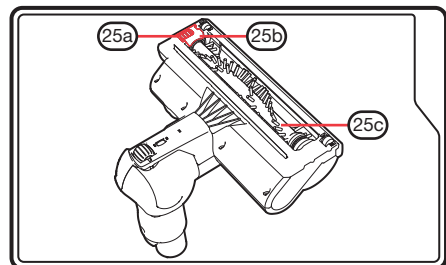

Remove the brush bar cover (25b) and lift the rotating brush bar (25c) out. Pull away any hairs or fibres from the rotating brush bar. If they are tightly wound around the brush, carefully snip the fibres with scissors, being careful not to damage the rotating brush bar, pull away from the rotating brush bar and dispose of. Replace the rotating brush bar and brush bar cover in their original position and re-lock the locking button (25a).

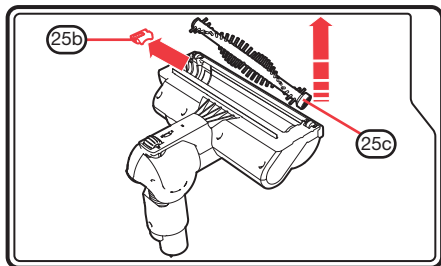

Maintenance - troubleshooting

- **“Does not pick-up”/ “Motorised floor-brush running slow or soon stops”**

Check for hairs/fibres that may be wrapped around the rotating brush-bar.

IMPORTANT: Remove the rotating brush bar as described on page 10. Fine hairs or fibres may be caught in the ends of the rotating brush bar. Carefully remove the hairs and re-fit the rotating brush bar.

- **“Does not pick-up” / “Suction of handheld cleaner has reduced”**
In addition to emptying the dust canister, it is very important that the filters inside the handheld cleaner are regularly and thoroughly cleaned. See page 9 and 10 for details of how to access and clean the filters.
- **“Does not pick-up from the floor but the motorised floor brush is rotating and the handheld has good suction”**
Switch off the product, remove the motorised floor brush and the extension tube and check for blockages in both.
- **“Product not charging”**
Check the charging / power indicator lights (4) on the top of the handheld vacuum cleaner are flashing to indicate that charging is in process. If the indicator is not showing, check: **a)** the mains adaptor (24) is correctly fitted into the charging inlet (3); **b)** the mains adaptor is fully fitted into the mains socket and the socket is switched on.

Disposal

When the product reaches the end of its useful life, it must not be disposed of in normal household waste. The product must be disposed of at an authorised recycling plant.

The battery should be removed and disposed of at an authorised recycling plant. Your local authority will have a centre which accepts such waste for recycling.

To remove the battery, press the battery release buttons on either side of the battery (13) and pull the battery away from the handheld vacuum cleaner (12).

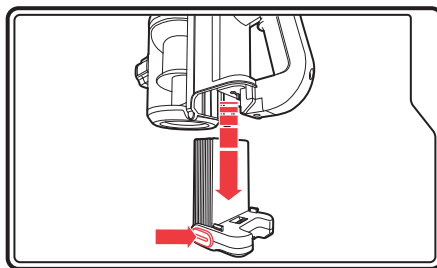

WARNING: Batteries and products containing batteries must never be disposed of in fires.

Contact us

Helpline

If you are having a problem with your appliance, please call our Helpline, as we are more likely to be able to help than the store you purchased the item from.

Please have the product name, model number and serial number to hand when you call to help us deal with your enquiry quicker.

UK Helpline: **0344 871 0944**
IRE Helpline: **1800 409 119**
Spares: **0344 873 0710**

Talk To Us

If you have any questions or comments, or want some great tips to help you get the most out of your products, join us online:

Blog: **www.morphyrichards.co.uk/blog**
Facebook: **www.facebook.com/morphyrichardsuk**
Twitter: **[@loveyourmorphy](https://twitter.com/loveyourmorphy)**
Website: **www.morphyrichards.com**

VC731005 MUK Rev1 10/16

Registering your 2 year guarantee

Your standard 1 year guarantee is extended for an additional 12 months when you register the product within 28 days of purchase with Morphy Richards. If you do not register the product with Morphy Richards within 28 days, your product is guaranteed for 1 year. To validate your 2 year guarantee, register with us online at

www.morphyrichards.co.uk

Or call our customer registration line

UK 0344 871 0242

IRE 1800 409 119

N.B. Each qualifying product needs to be registered with Morphy Richards individually.

Please note that the 2 year guarantee is only available in the UK and Ireland. Please refer to the 1 year guarantee for more information.

Your 1 year guarantee

To qualify for the 1 year guarantee, the appliance must have been used according to the instructions supplied.

It is important to retain the retailer's receipt as proof of purchase. Staple your receipt to this back cover for future reference.

Please quote the following information if the product develops a fault. These numbers can be found on the base of the product.

Model no.

Serial no.

All Morphy Richards products are individually tested before leaving the factory. In the unlikely event of any appliance proving to be faulty within 28 days of purchase, it should be returned to the place of purchase for it to be replaced.

If the fault develops after 28 days and within 1 year (2 years if registered) of original purchase, you should contact the Helpline number quoting Model number and Serial number on the product, or write to Morphy Richards at the address shown.

You may be asked to return a copy of proof of purchase. Subject to the exclusions set out below (see Exclusions), the faulty appliance will then be repaired or replaced and dispatched usually within 7 working days of receipt.

If you suspect a fault, follow the simple checks detailed below before retrying the appliance or calling the helpline.

- Check the filters for blockages and clean.
- Check the tools / tubes for blockages.
- Check the appliance is charged.
- Check the socket used for charging is working and the charging adaptor is firmly in the socket during charging.

If, for any reason, this item is replaced during the 1 year guarantee period, the guarantee on the new item will be calculated from original purchase date. Therefore it is vital to retain your original till receipt or invoice to indicate the date of initial purchase. To qualify for the 1 year guarantee, the appliance must have been used according to the instructions supplied.

This appliance is intended for domestic use only. Misuse or use for commercial or any other purpose will render the guarantee invalid.

Exclusions

Morphy Richards shall not be liable to replace or repair the goods under the terms of the guarantee where:

- 1 The fault has been caused or is attributable to accidental use, misuse, negligent use or used contrary to the manufacturer's recommendations or where the fault has been caused by power surges or damage caused in transit.
 - 2 The appliance has been used on a voltage supply other than that stamped on the products.
 - 3 Repairs have been attempted by persons other than our service staff (or authorised dealer).
 - 4 The appliance has been used for hire purposes or non domestic use.
 - 5 The appliance is second hand.
 - 6 Morphy Richards reserves the right not to carry out any type of servicing under the guarantee at its discretion.
 - 7 The guarantee excludes consumables such as the filter.
- This guarantee does not confer any rights other than those expressly set out above and does not cover any claims for consequential loss or damage. This guarantee is offered as an additional benefit and does not affect your statutory rights as a consumer. Morphy Richards products are intended for household use only. See usage limitations within the location safety instructions.

Disclaimer

Morphy Richards has a policy of continuous improvement in product quality and design. The company, therefore reserves the right to change the specification of its models at any time.



For electrical products sold within the European Community. At the end of the electrical products useful life, it should not be disposed of with household waste. Please recycle where facilities exist. Check with your Local Authority or retailer for recycling advice in your country.



Battery should be removed at the end of the product's life for recycling.

Li-ion

**IF YOU ARE HAVING A PROBLEM
WITH ONE OF OUR PRODUCTS,
CALL OUR HELPLINE:**

**UK: 0344 871 0944
EIRE: 1800 409 119
SPARES: 0344 873 0710**

morphyrichards

The After Sales Division
Morphy Richards Ltd
Mexborough,
South Yorkshire,
England, S64 8AJ

www.morphyrichards.com

